



**wessex**  
**DOORS**

# Garage Door

fitting instructions

## Unframed Canopy Fitting Instructions V4.3

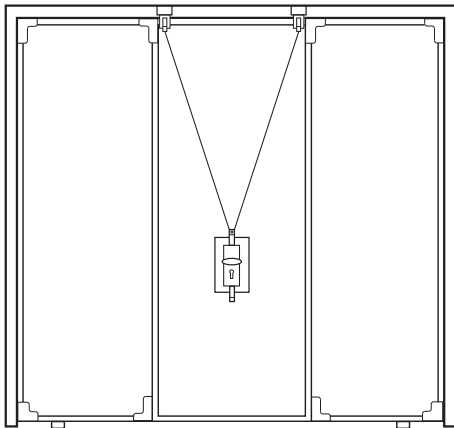

### Warning!



Garage doors are under extreme pressure from the spring system and a poorly installed frame could lead to serious injury if the door comes loose or falls in any way.

## Before you start!

### Measure

Measure the timber frame opening is the advertised size of the door. For instance, if you have purchased a 7' x 7' door then the internal frame opening should be 7' x 7' as the door is delivered slightly smaller to give opening tolerances. Check the frame is square and there is the space required inside the garage to ensure that the door will not be impeded by anything in the garage.

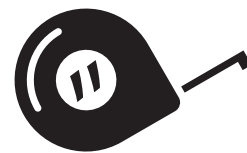

### Pack Contents

#### 1x fitting pack containing:

- 20x 30mm wood screws Phillips head
- 8x M8 washers
- 8x M6 Coach screws hex head
- 3x keys
- 1x door
- 1x handle pack

### Frame Requirement

This door is ready to install to your timber frame (not supplied). This must be a minimum 60mm square (ideal size 70mm square). It must also be sound and free from any rot, splits or damage.

### Tools required for installation:



Screw driver



Pliers



Tape measure



Electric drill

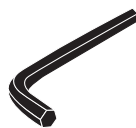

Allen key



Spanner



Spirit Level



Wedge

### Safety Equipment



Gloves



Goggles

Wear adequate protection when installing

## Handy information:

### Caution!



Garage doors are heavy and this item must be installed by two people.

### Do not!



Do not allow children to assist in the installation, adjustment, or operation of this door. Garage doors can inflict severe injury if not used correctly.

### CE Marked



This door is CE marked and comes with a Europe wide 2 year warranty, limitations apply visit **[www.wessexdoors.co.uk](http://www.wessexdoors.co.uk)** and view full terms and conditions.

### Warranty



Always ensure the door is correctly adjusted and serviced as failure to do so may invalidate the warranty.

### Warning!



Until all parts of the installation are finished, there is a possibility of being locked out, always ensure someone is inside until you have checked the operation of the lock and adjusted as required.

### For technical help:

Helpline: 01217 497 977

Email: [sales@wessexdoors.co.uk](mailto:sales@wessexdoors.co.uk)

Website: [www.wessexdoors.co.uk](http://www.wessexdoors.co.uk)

## Attaching the spring holders

Remove the side tracks by cutting the cable ties. **Note the correct arrangement of the bottom wheel as this is vital later.**

Measure the door panel and the precise location of the top latch assembly. Now fit two spring holders as shown below using 3 x 30mm wood screws. (Alternatively place door in opening and mark where latches are to be fitted).

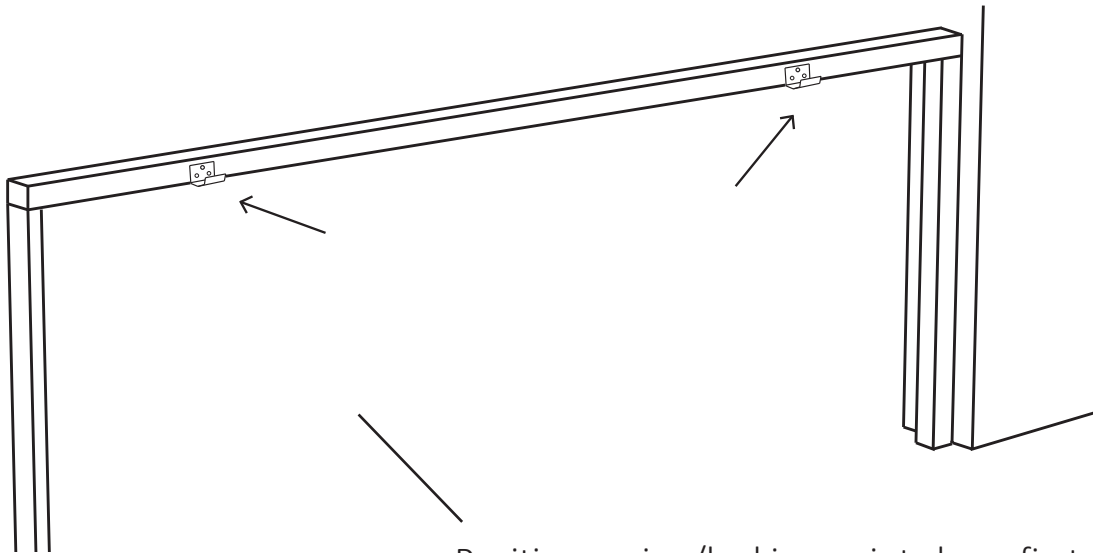

Position spring/locking points here first. Measure the lock distance on the door to determine the correct position. Align the bottom of the bracket with the bottom edge of the frame.

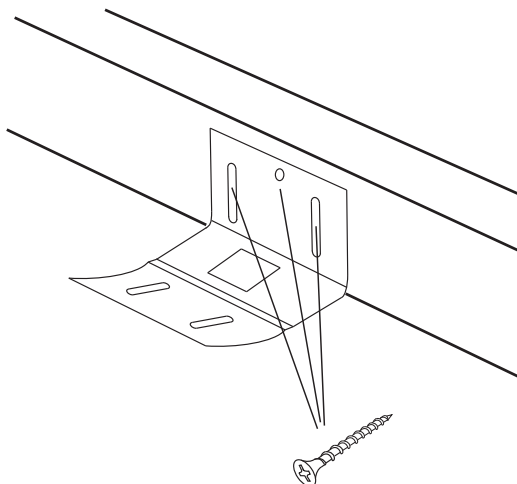

Please note design change. You may need 4 screws on this item not 3.

### Tip



Check the timber is sound. You are about to screw a highly tensioned spring to the cross bar. Ask yourself, is it strong enough? Any signs of rot then change it. If it is loose, fix it so its solid.

## Installation

Offer the door up to the opening (**two persons required**) and wedge in to place, use a spirit level to ensure the overall satisfactory look of the installation and in particular the level of the frame head is correct.



### Tip!

It's good to have someone outside for levelling the door, concentrate on the sides as this is the most obvious part if the installation is out of alignment. Ensure that when you stand back the door looks evenly spaced in the hole. Try not to rush this part as its not easy to put right after you have fixed the screws in place.

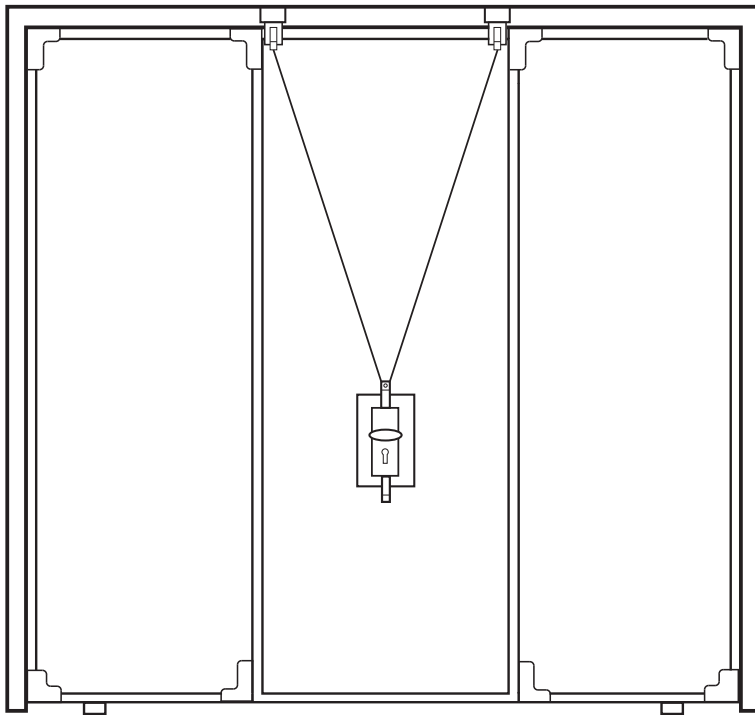

Timber wedges to lift door into correct position.

Look for around 8-10mm per gap all around.

## Slamming strip

You will need a slamming strip at the front after installation. We recommend you tack on a 1" square piece of timber (not supplied) butted up to the front of the door. This will stop potential attack to the locking points at the top from outside (see picture below).

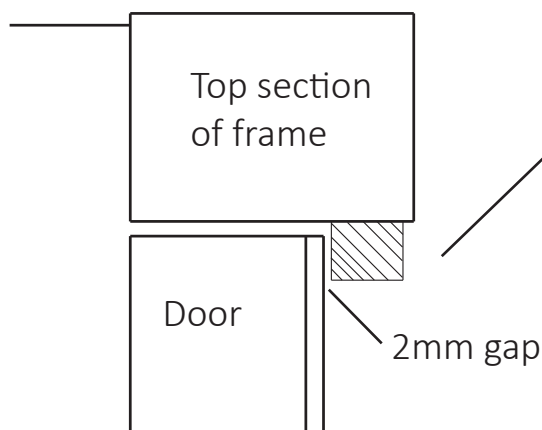

1" square slam strip nailed on the frame the full length of the door at the top with a 2mm gap to the face of the door. If it is too tight the door locks wont engage.

## Top spring positioning

### Check the following

- The red and white drum at the end of the spring system do not foul the brickwork either side.
- The cables run from the back of the cones against the frame to the wheel assembly.

When satisfied with the door position move the spring left or right so that the side arms are level either side. Ensure the black side seal (white steel on some doors) on the door can pass through the arms. The fixing bracket on the left is not fixed and you should ensure this is pushed tight against the white drum.

Now using the 4 x 50mm coach screws fix the top spring assembly into place. The bottom edge of the bracket should be in line with the bottom edge of the frame head.

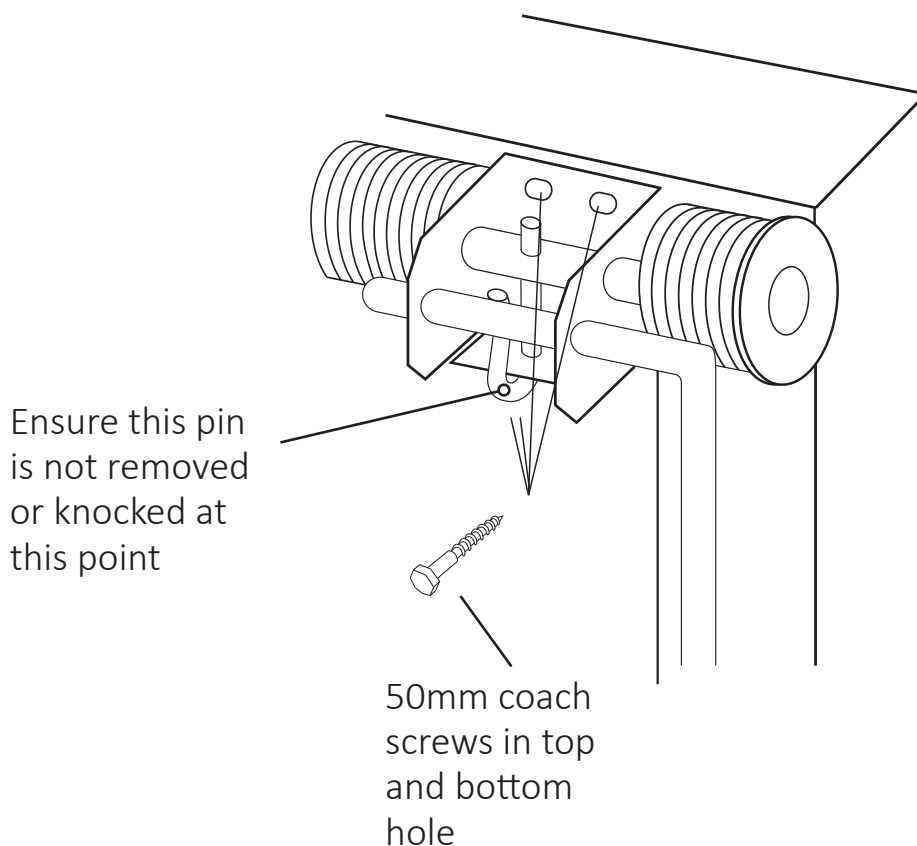

## Top spring positioning



### Tip!

Ensure the bracket is flat against the frame top and bottom. If its tilted when you tighten the coach screws the door will lift!

Once you tighten it's almost impossible to get a good fixing a second time around. Check the cables are in the groove furthest from the door and run down the back of the frame.

Check the door will pass the arms either side at the top.

## Fitting the tracks

Slide the left and right side track over the wheel and anti drop device as shown. The bottom edge of the track should be around 35mm below the bottom edge of the wheel. Fix the track in place using 3x 30mm wood screws per side.

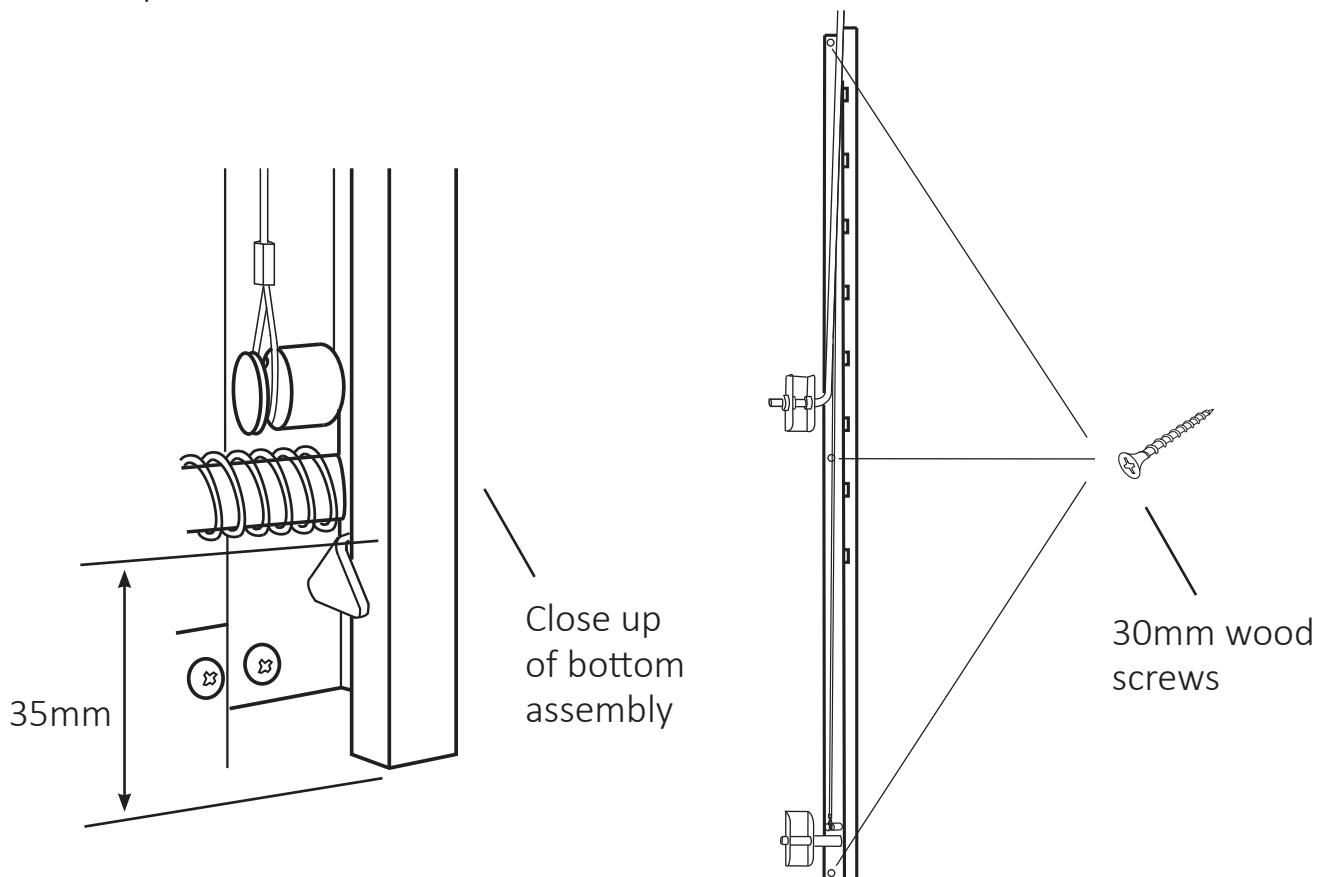

## Fitting the tracks



### Tip!

Ensure the side track is level as failure to do so will bind the door movement making the unit very stiff. The square holes in the track are at the top. The holes are designed as a safety feature and the wheel assembly will not engage the holes unless there's a cable failure.

## Pull the transit pin

Using a pair of pliers pull out the pin you avoided previously in the instructions. The pin holds the tension during transit. The pin loads the tension onto the cables and allows the door to operate. It will be stiff so you may need to wiggle it to release.

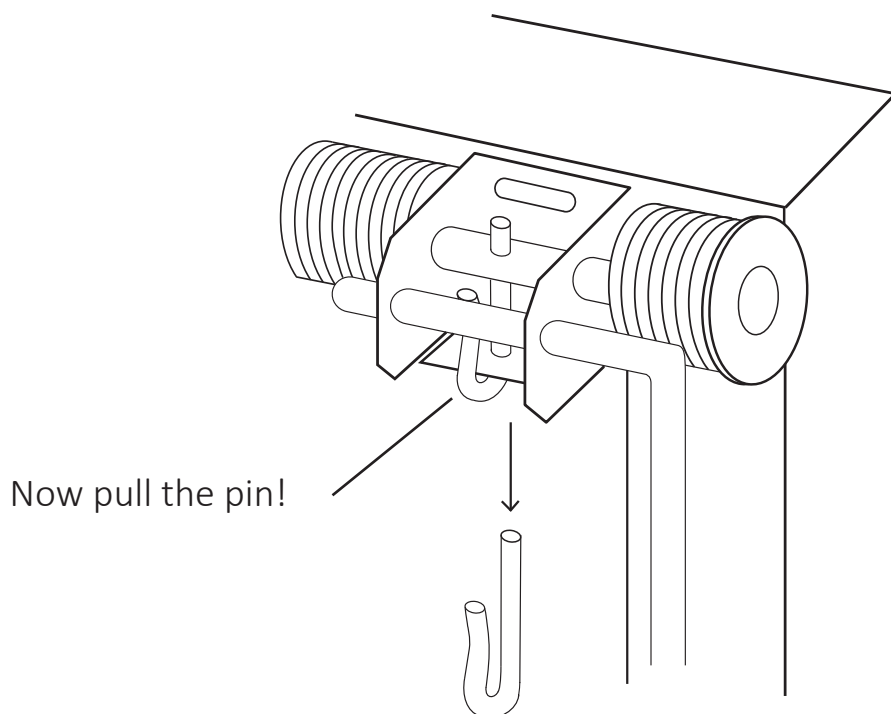



## Fitting the outer handle

Fit the outer handle to the outside of the door , fit the inner lock and the moulded fixing using an Alan key and tighten.

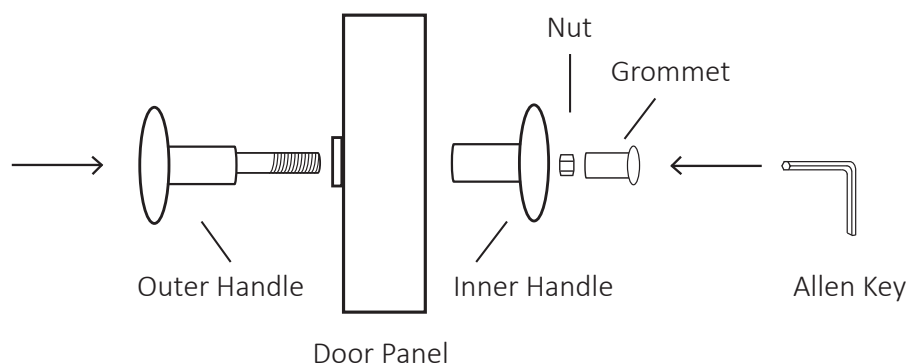

### Caution!

Only tighten enough to remove play from handle - over tightening can damage the outer panel.

## Door commissioning and adjustment

Open the door fully and oil the side runners and the wheels / cables and top latches. **If 4 point locking purchased see separate sheet and fit now.**

### Caution!

Check the locking works correctly from the inside by closing the door and opening again. Do not do this from the outside as if adjustment is required you may not be able to open the door again.



Although adjusted in the factory the cables can be disturbed during transport and it is the responsibility of the installer to correct the cables as required. Now oil the tracks / lock and latches and all moving parts – do not grease any part.

### Adjustment

If the door is opening too slowly or too quickly adjust the tension on the spring (see spring tension adjustment). **Call the technical helpline on 01217 497 977 for advice** - this element should only be performed by competent persons.



## Important

### Cables



Locking cables and lifting cables are subject to wear and tear and should be examined regularly, tangling of cables through poor maintenance/adjustment does not constitute as a manufacturing defect.

### Cable failure



The holes in the tracks on either side are a safety device. Only expect them to engage if you have a cable failure - they are designed to stop the door falling on your head!

## Spring Tension Adjustment

First, replace the pin to add or remove tension.

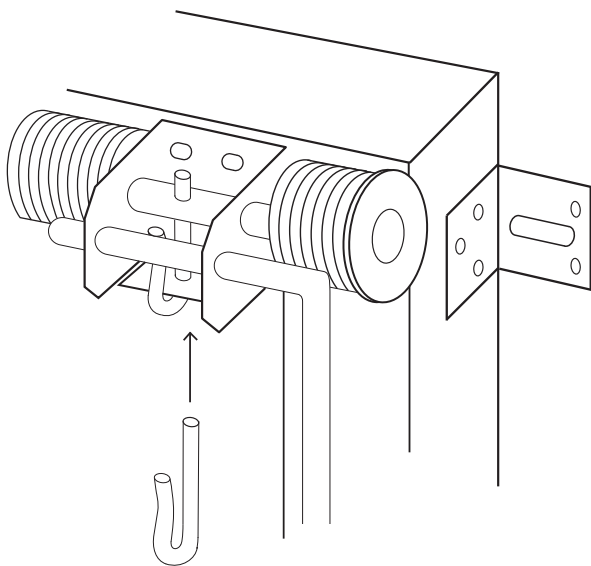

Replace the pin!

The spring is held with 2 grub screws that are on the knuckle on the left hand side of the spring.

There are also 4 holes in the knuckle for inserting suitable bars to adjust the tension - a spanner can also be used.

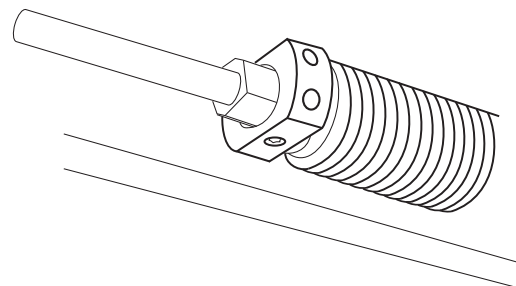

## Spring Tension Adjustment

When the grub screws are undone the tension is released so the spring must be held with the bars or 1 bar and a spanner.

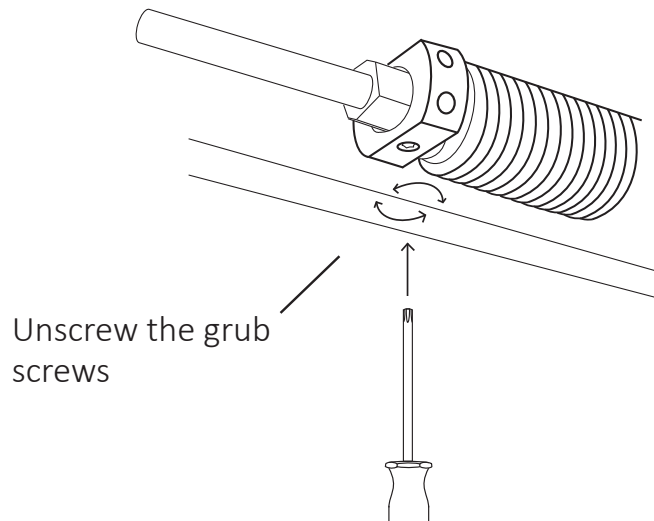

The tension is increased by turning the spring knuckle toward the ceiling and decreased by turning down.

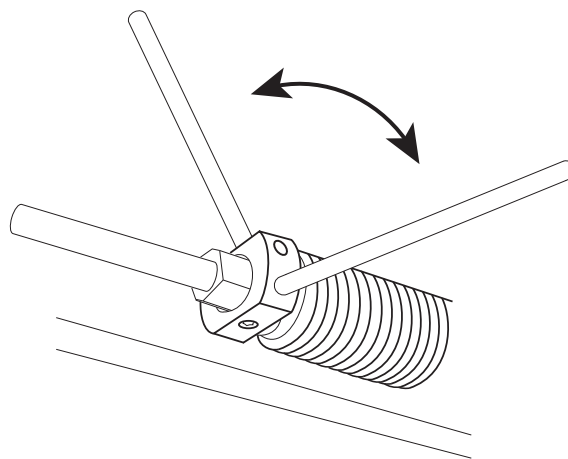

### Remember



The spring must be held with the bars at all times while the grub screws are loose to avoid the complete loss of tension.

Increase or decrease tension and tighten the grub screws with an allen key. Repeat until tension is correct. The pin must be removed to try the door tension. Make sure the cables are both in the correct grooves.

### Removal

Replace the crook pin removed on page 8. Unwind all spring tension using bars, remove screws in reverse order and remove door.



## EC Declaration of Conformity



We, the Wessex Doors company of the United Kingdom, do hereby declare that the building industry product described in the detail below conforms in all respects and meets all requirements if assembled and maintained in accordance with the installation instructions.

**Product** Wessex overhead garage door for manual operation

**Standard** Industrial, commercial and garage doors and gates -  
Product standard - Part 1: Products without fire resistance  
or smoke control characteristics.

EN 13241-1

EN 12604 Mechanical aspects - requirements

EN 12605 Mechanical aspects - test procedures

We furthermore declare that the technical documents including test certificates will be made available to the relevant governing authority upon request.

Authorised persons for the compilation and management of the technical documentation:

The Directors  
Wessex Doors  
25/06/2013



**wessex  
DOORS**

Wessex Doors, Unit 19, The Fort Industrial Park,  
Dunlop Way, Birmingham B35 7AR

Tel: 0121 749 3699

Fax: 0121 748 2677

e-mail: [sales@wessexdoors.co.uk](mailto:sales@wessexdoors.co.uk)

web: [www.wessexdoors.co.uk](http://www.wessexdoors.co.uk)

Wessex Doors reserves the right to alter specifications to design and manufacture without notification. All specifications are correct at time of publication, errors and omissions excepted. Colour samples are, due to the print process, intended as a guide only, please request a sample if unsure.